

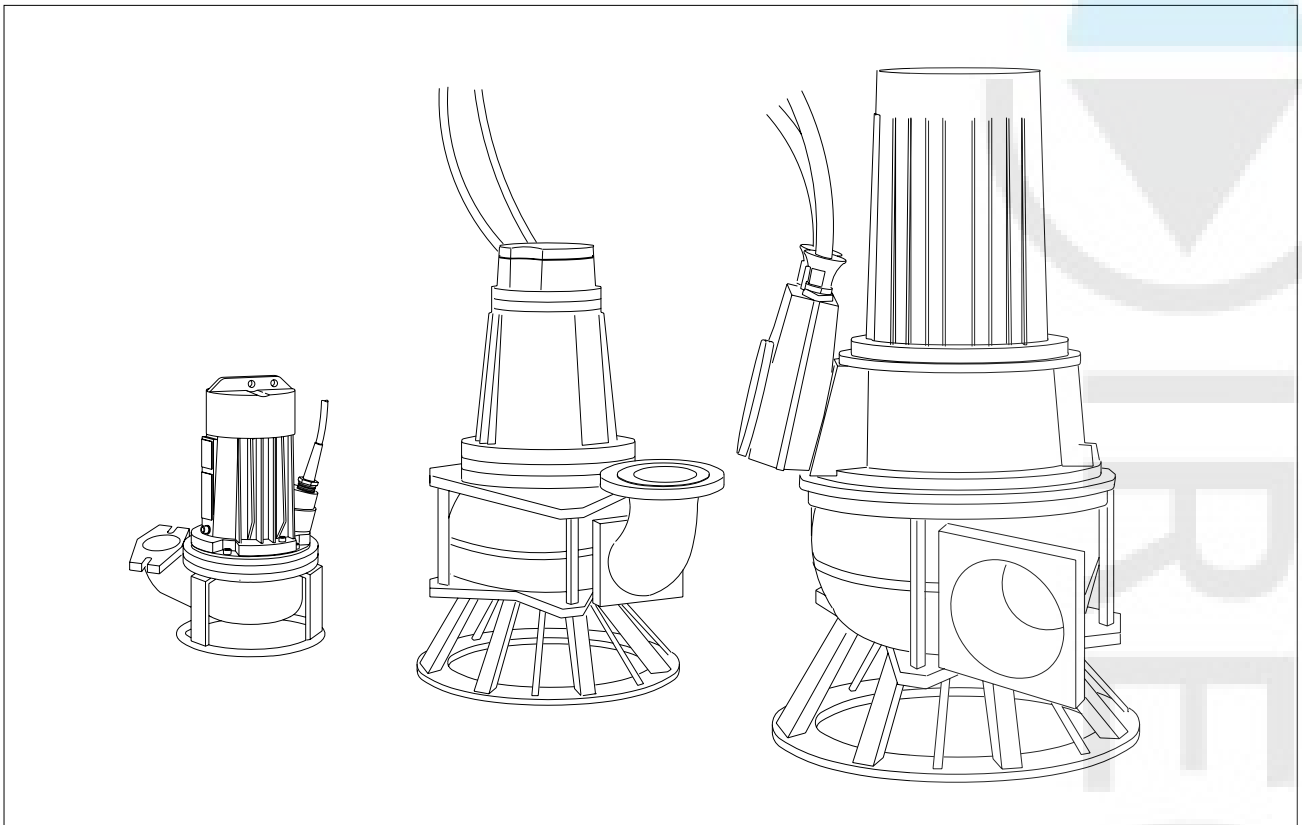

# OPERATION & MAINTENANCE MANUAL RD-SERIES



<b>Contents .....</b>	<b>page</b>
<b>1. FOREWORD .....</b>	<b>4</b>
<b>2. GUARANTEE .....</b>	<b>4</b>
<b>3. SAFETY AND ENVIRONMENT .....</b>	<b>5</b>
3.1 Symbols .....	5
3.2 General safety instructions .....	5
3.3 Environment .....	5
<b>4. TECHNICAL DATA .....</b>	<b>6</b>
4.1 General .....	6
4.2 Main parts .....	6
<b>5. FIRST PUMP START .....</b>	<b>7</b>
5.1 Delivery check .....	7
5.2 Oil level .....	7
5.3 Power supply .....	7
5.4 Thermoswitches .....	7
5.5 Cable entry .....	7
5.6 Motor protection .....	7
5.7 Motor check .....	8
5.8 Installation parts .....	8
5.9 Direction of rotation .....	8
5.10 Current-check .....	8
5.11 Medium temperature / max. motorload .....	9
5.12 Start frequency .....	9
5.13 Min. and max. submersible depth .....	9
<b>6. INSTALLATION OPTIONS .....</b>	<b>10</b>
6.1 Installation -H .....	10
6.2 Installation -V .....	11
6.3 Checkpoint installation -V .....	12
6.4 Installation -F .....	13
6.5 Installation -T .....	13
<b>7. MAINTENANCE .....</b>	<b>14</b>
7.1 General .....	14
7.2 Maintenance schedule .....	14
7.3 Lubricants .....	14
7.4 Cable entry .....	15
7.5 Oil level .....	16
7.6 Oil change .....	17
7.7 Motor housing .....	18
<b>8. TRANSPORT AND STORAGE .....</b>	<b>19</b>
<b>9. OPTIONS .....</b>	<b>20</b>
9.1 Waterdetector .....	20
9.2 Thermoswitches .....	20
9.3 Thermistors .....	20
9.4 Cable protecting .....	21
9.5 Special oil .....	21
9.6 External cooling system .....	21
<b>10. TROUBLE SHOOTING .....</b>	<b>22</b>
<b>APPENDIX 1; Dataplate .....</b>	<b>23</b>
<b>APPENDIX 2; Direct-on-line start motor .....</b>	<b>24</b>
<b>APPENDIX 3; Star-delta start motor .....</b>	<b>26</b>
<b>APPENDIX 4; Notes .....</b>	<b>28</b>

## 1. FOREWORD

You are to be congratulated on choosing a ROBOT RD pump, which will undoubtedly serve you both reliably and economically for a long time, providing you observe the Maintenance Instructions given in this manual.

The RD-pump is a dredging pump, designed for the transport of highly abrasive solids.

Proper use and maintenance will prolong the operational life of your RD- pump.

This manual contains different warnings and safety precaution.

Read this manual properly, so that dangerous situations, physical injury or damage can be avoided.

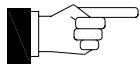

The RD-pump is designed for professional use only. Service and maintenance may only be done by authorized personnel, after reading this manual.



The RD-pump in basic version may not be used in a potentially explosive atmosphere.

## 2. GUARANTEE

We refer to the warranty agreement with your local dealer.

When ordering spareparts, always quote.

1. Pump type
2. Code
3. Serial number

This information is found on the dataplate. (See appendix 1)

Sectional drawings and partslists are available on request.

All products manufactured by Robot Pumps B.V. are made with great care and according to our high internal standards. Should you however have any suggestions concerning our pump range or this instruction manual which will contribute to the quality of our product please do not hesitate to contact us.

**POMP DIRECT**

T +31 29 445 77 12  
info@pompdirect.nl

Bloemendalerweg 14  
1382 KC Weesp (NL)

### 3. SAFETY AND ENVIRONMENT

#### 3.1 Symbols

\* In this manual



General warning  
Danger !



Electrical hazard !

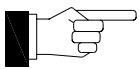

Attention !

\* On the pump



Danger of physical injury  
Rotating parts !



Electrical hazard !



EC-conformity symbol

#### 3.2 General safety instructions

- \* Only trained and authorized personnel may install and maintain the pump after carefully reading this manual.
- \* Only use the pump for its intended purpose and under the regulated circumstances.
- \* Don't go near rotating parts.
- \* Clean the pump before maintenance and inspection.
- \* Observe the local regulations when working with aggressive, corrosive, toxic, flammable and explosive chemicals.
- \* Never remove safety signs, keep them clean.
- \* Always connect to a grounded circuit.
- \* Before maintenance and inspection always disconnect the pump from the mains.
- \* Use a proper hoist for lifting and handling the pump.
- \* Do not leave a large loop of cable in the sump, as the pump may eventually damage it.
- \* Never drop the loose cable end in water.

#### 3.3 Environment

Parts which are replaced during repair, maintenance or renewal, could contain materials which could be harmful to the environment.

Please take care in the disposal of these parts.  
Do this in accordance with the local environmental regulations.

## 4. TECHNICAL DATA

### 4.1 General

The RD-pump is dredging pump, specially designed for transport of highly abrasive solids.

Apart from dredging, the pump can be used in mining, construction works and industry.

The impeller leaves a wide unobstructed passage through the volute, in which a strong vortex is created that carries most of the solids.

### Construction:

- High efficiency motor, standard class F insulation (up to 155°C).
- Two independent mechanical seals, running in oil, form an effective barrier between pump and motor.
- Heavy duty bearings, greased for life.
- Clog-free vortex impeller.
- Agitator, to feed the impeller with solids.
- All hydraulic components in Nihard 4.
- Vanes at the backside prevent solids entering the seal area and reduce the pressure on the seal.

### 4.2 Main parts

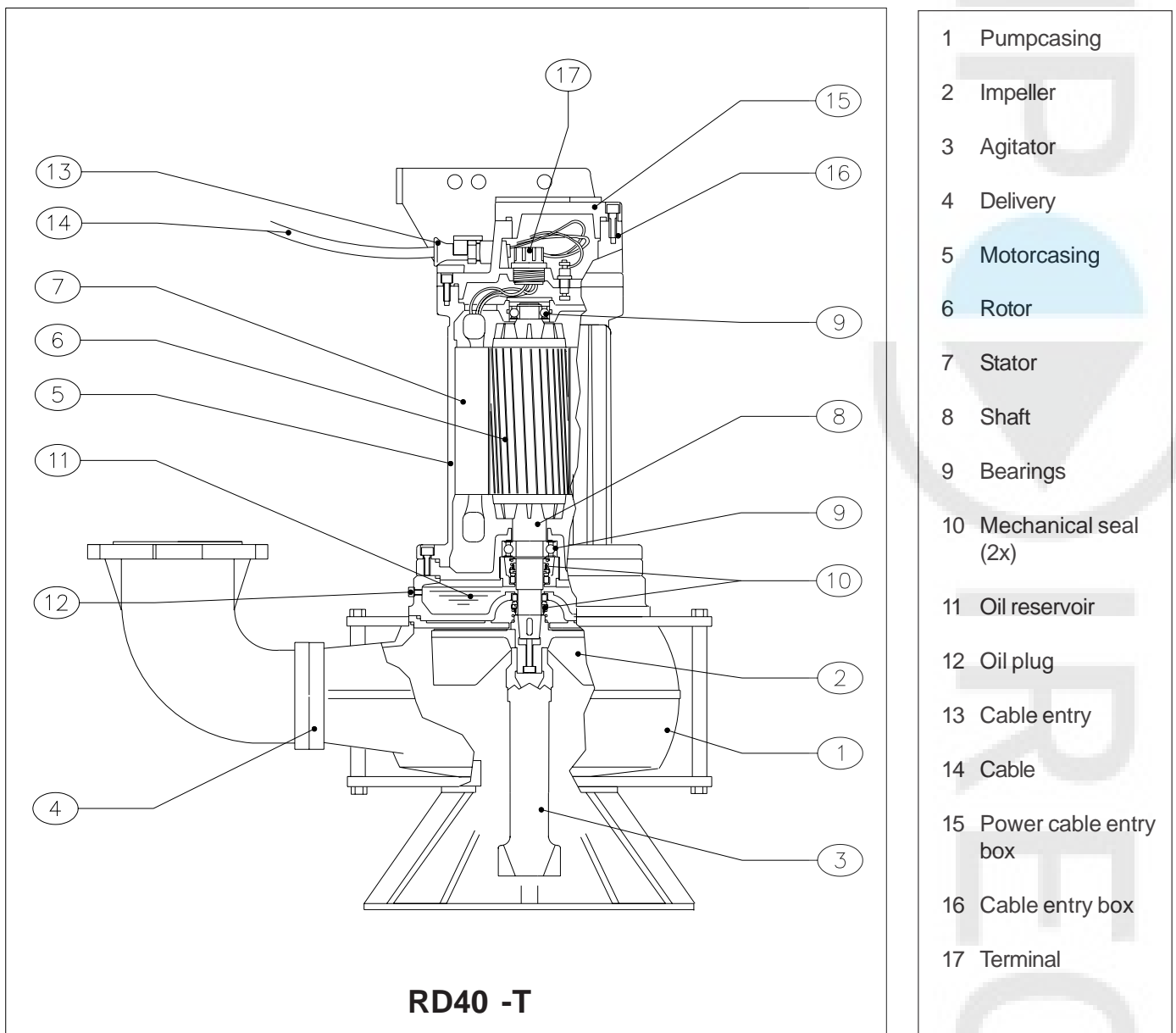

Fig.4.1

## 5. FIRST PUMSTART

After unpacking the pump, carry out the following check points:

### 5.1 Delivery-check

Check for possible transport damage and especially check that the cable has not been nicked or damaged.

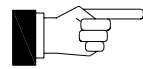

Check for complete delivery.

When the delivery is incomplete or damaged, please contact your dealer immediately.

### 5.2 Oil level

Check the oil level. (see 7.5)

### 5.3 Power supply

Before making the electrical connections, check if the line voltage and frequency are the same as on the pump dataplate.

If thermostats are supplied make sure that they are correctly connected.

For examples of electrical diagrams and pump cable coding, see appendix 2 and 3.

### 5.4 Thermostitches

Check if the pump is equipped with thermostitches (optional for RD20 and RD40, standard for RD60-series).

Contact rating: max. 250V-1.6A

The contacts are normally closed.

### 5.5 Cable entry

Especially when the pump has been in store for a long time, the cable gland should be checked and if necessary tightened (see 7.4).

### 5.6 Motor protection

The pump should always be connected to the line by means of a suitable motor protection circuitbreaker.

If the pump is started direct on line (DOL), the protection breaker should be set to the current, as given on the dataplate.

For star delta start (YD), it is good practice to install the overcurrent relay directly after the main contactor. In this case, the pump is also adequately protected in star-connection.

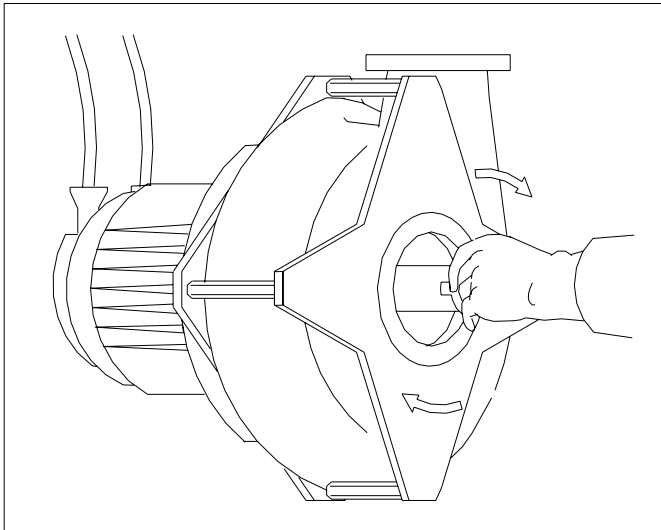

Fig. 5.1

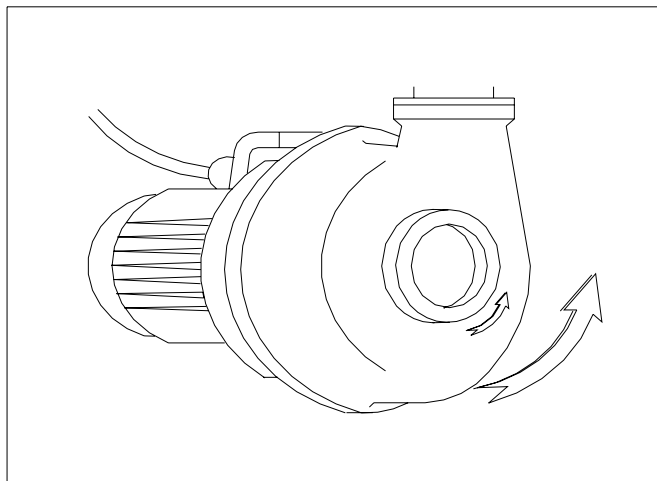

Fig. 5.2

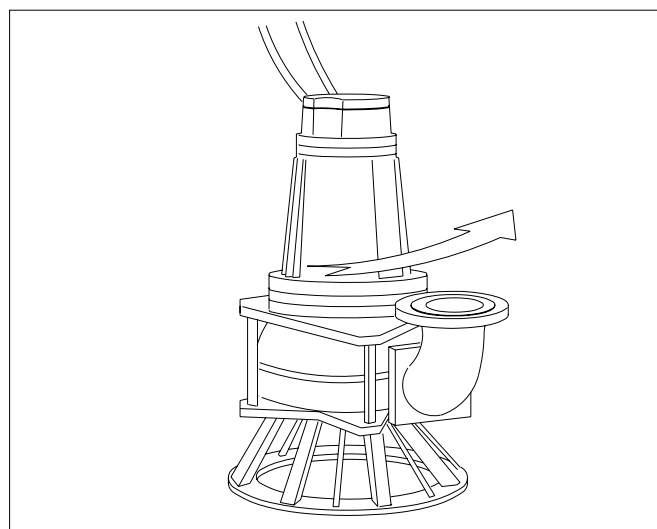

Fig. 5.3

### 5.7 Motor check

If in doubt about the condition of the motor or cable, Megger test motorwindings against grounding wire. The phase resistance against grounding wire should be at least 1 MOhm.

Turn the impeller counter-clockwise by hand (see fig.5.1) . For versions without agitator, use a proper socket wrench. This should be possible without much force. With this procedure sticking mechanical seal surfaces will be loosened smoothly.

### 5.8 Installation parts

Check if all components for your installation are delivered. See also chapter 6.

### 5.9 Direction of rotation

A correct direction of rotation is essential for proper operation. This can be checked as follows:

- Put the pump in horizontal position and start the pump.  
Looking on the impeller through the suction opening, the correct direction of rotation is counter-clockwise  
(See arrow on pumpcasing, Fig. 5.2).

or:

- Starting the pump will give a recoil on the pump frame.  
Looking at the motor (in vertical position see Fig. 5.3), the recoil is counter-clockwise.



Take care !  
The recoil can be very powerful !  
Don't go near rotating parts !

### 5.10 Current-check

Note the max. current from the dataplate. Apply an ammeter to one of the phase wires during normal operation. Check that the current is not higher than the value on the dataplate. (see appendix 1). If so check for:

- voltage (too low ?)
- specific gravity or viscosity of the fluid (too high ?)
- blocked impeller ?
- direction of rotation correct ?

If the problem cannot be solved contact your dealer.

**5.11 Medium temp. / max.motorload**

When the medium temperature is higher than 40°C, the maximum motorload must be reduced.  
 The relationship between medium temperature and maximum absorbed motor current is shown below. Check the reading of the dataplate against the reading of an Ammeter.  
 If the motor current exceeds the max. motorcurrent from the table below the pump is not suitable or the motorcurrent must be reduced.  
 The motorcurrent can be reduced by installing a smaller impeller. Contact your dealer.

Temperature		Max.motorcurrent
°C	°F	%
40	104	100
50	122	95
60	144	90
70	158	80
80	176	70

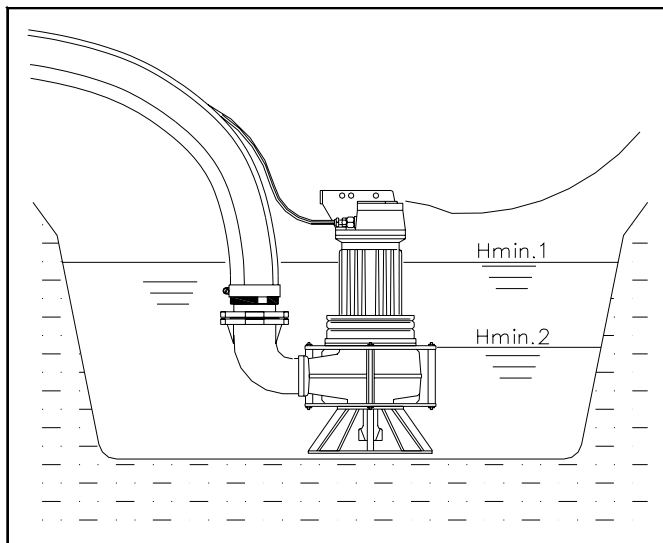

Fig. 5.4

**5.12 Start frequency**

When the pump is controlled by level regulators, the on and off levels should be adjusted in such a way, that the pump does not do more than 20 starts per hour.

**5.13 Min. and max. submersion depth**

The motorhousing should be at least 2/3 submerged for continuous operation at full load. (see Hmin.1 Fig. 5.4)  
 It is good practice, whenever possible to keep the motorhousing completely under water.

For interrupted level controlled operation, less cooling is required. We recommend not to run the pump with the water level below the top of the volute in order to avoid air being drawn in (see Hmin.2 Fig. 5.4).  
 Air in the discharge pipes might impair performance.

The maximum submersion depth is 20m / 60ft.



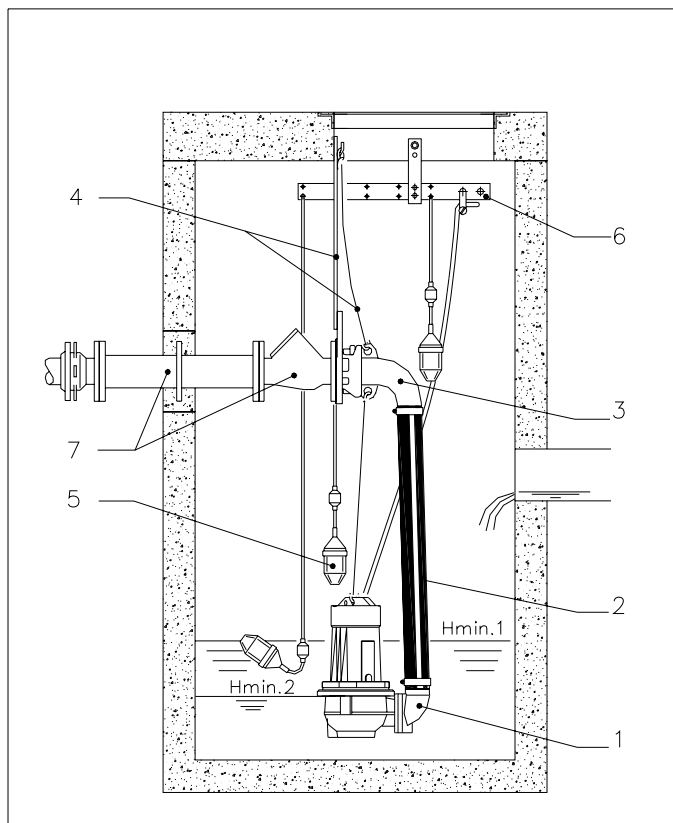

Fig. 6.1

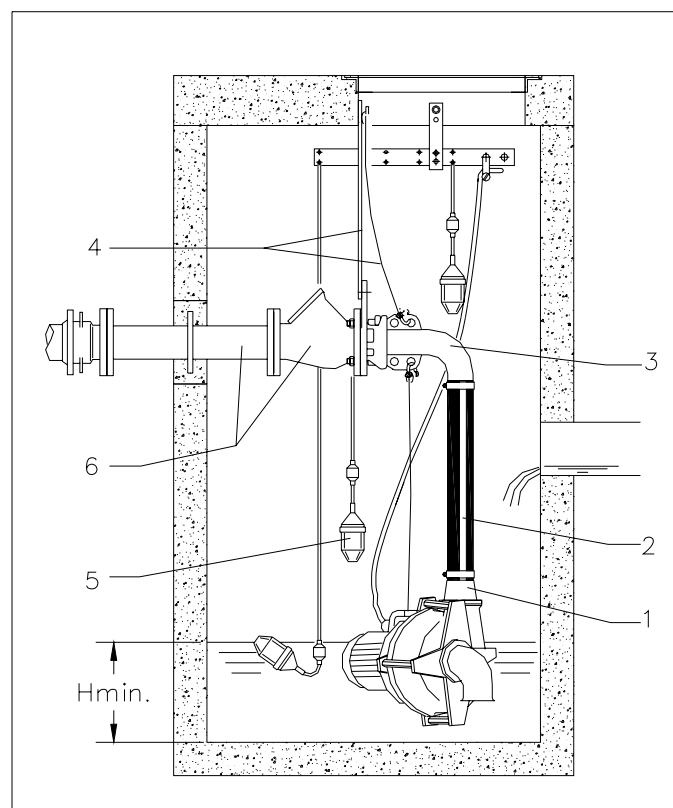

Fig. 6.2

## 6. INSTALLATION OPTIONS

For the submersible pump the following installations are possible:

- H Stationary wet installation with a header coupling type HK.
- V Stationary wet installation with a guide bar quick release coupling type V.
- F Freestanding wet installation.
- T Transportable wet installation.

### 6.1 INSTALLATION - H

Stationary wet installation with a ROBOT quick-release header coupling type HK.

A flexible hose connects pump and coupling.

RD20 pumps will have a vertical position, see Fig. 6.1. All other RD pumps are horizontally placed, see Fig. 6.2.

Except for the pump the following components are necessary:

1. Hose connection, which is fastened to the pump;
2. Flexible hose, between pump and coupling;
3. Header coupling, consisting of coupling bend, rubber joint and a fixed coupling part;
4. Suspension bracket and chain, for lifting the pump;
5. Level regulators for start-, stop- and alarm-signals;
6. Suspension for level regulators and power supply cable;
7. Piping, non return valve, bends etc.

Checkpoints before operating:

- Ensure a good free passage beneath the suction opening of the pump (at least the same as the suction diameter).
- Adjust the start- and stop levels in such a way that the motor does not make more than 20 starts per hour .
- Check that the motor is adequately cooled. The motorhousing should be at least 2/3 submerged for continuous operation at full load (see Hmin.1 Fig. 6.1). It is good practice, whenever possible to keep the motorhousing completely under water. For interrupted level controlled operation, less cooling is required. We recommend not to run the pump with the water level below the top of the volute in order to avoid air being drawn in (see Hmin.2 Fig. 6.1). Air in the discharge pipes might impair performance.

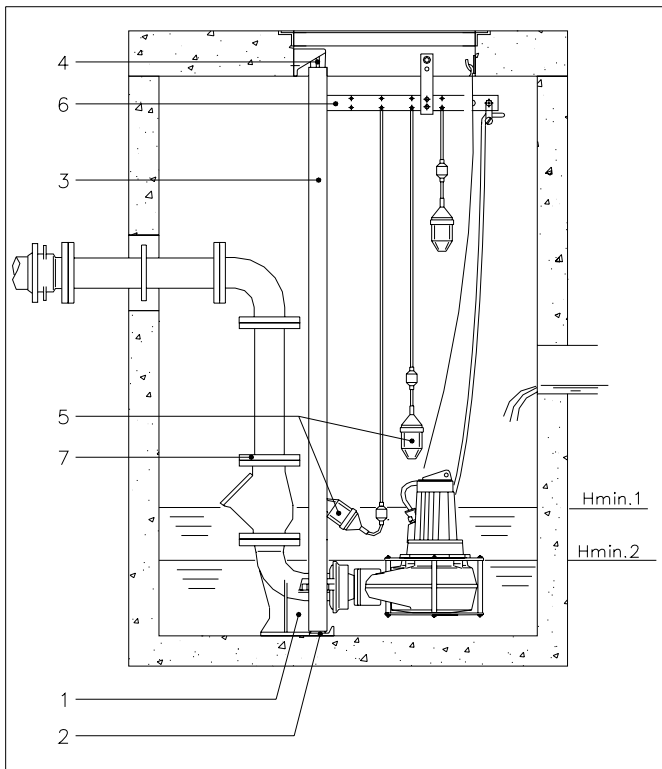

Fig. 6.3

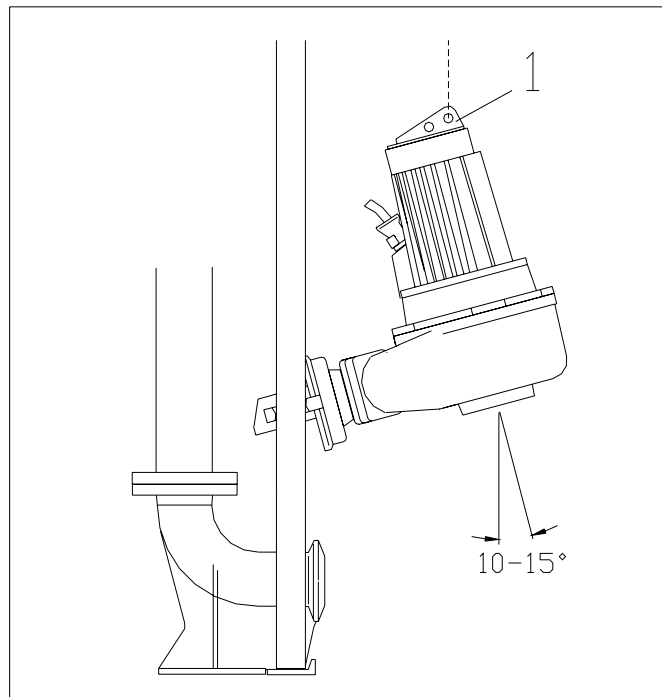

Fig. 6.4

## 6.2 INSTALLATION -V

Stationary wet installation with a ROBOT quick-release guide bar coupling type -V. The pump is automatically coupled to the discharge.

Except for the pump the following components are necessary:

1. Bottom elbow, rubber joint and coupling adapter;
2. Guide bar foundation plate;
3. Two guide bars
4. Top bracket, mounted within the wellcover clearance;
5. Level regulators for start-, stop- and alarm-signals;
6. Suspension for level regulators and power supply cables;
7. Piping, non return valve, discharge bends etc.

Checkpoints before operating:

- Both guide bars must stand vertical (maximum tolerance 3°).
- The installation angle must be about 10-15° (see Fig. 6.4). If necessary, this angle can be changed by alteration of the position of the lifting hook on the suspension bracket on top of the motor (pos. 1).
- Adjust the start- and stoplevels in such a way that the motor does not make more than 20 starts per hour.
- Check that the motor is adequately cooled. The motorhousing should be at least 2/3 submerged for continuous operation at full load (see Hmin. 1 Fig. 6.3). It is good practice, whenever possible to keep the motorhousing completely under water.

For interrupted level controlled operation, less cooling is required.

We recommend not to run the pump with the water level below the top of the volute in order to avoid air being drawn in (see Hmin.2 Fig. 6.3).

Air in the discharge pipes might impair performance.

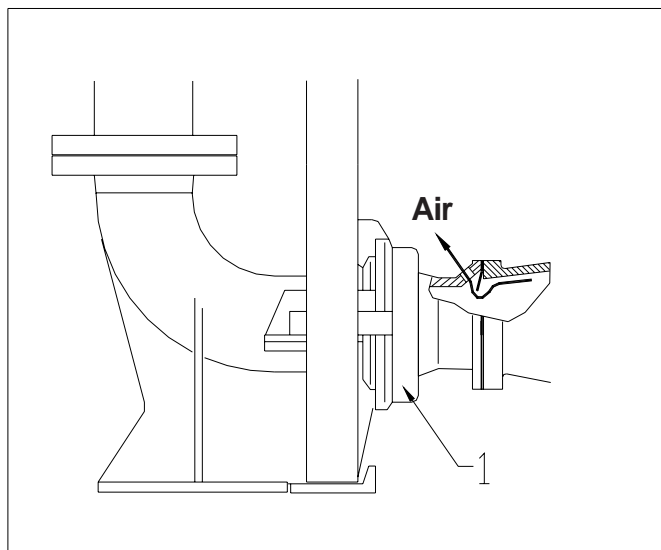

Fig. 6.5

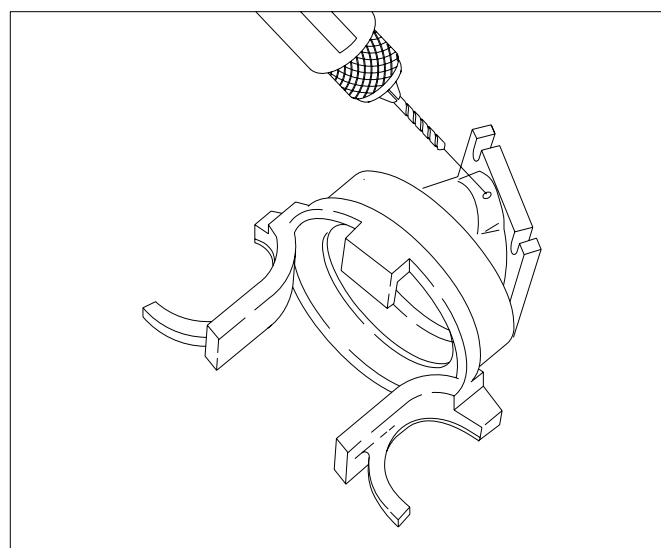

Fig. 6.6

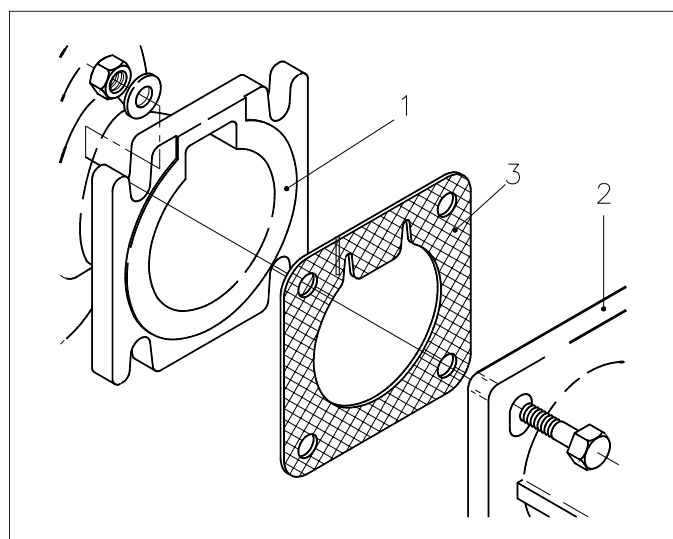

Fig. 6.7

### 6.3 Checkpoint installation - V

In some applications it is possible that the pump will not work due to presence of air in the volute.

Lifting the pump a bit (10-20mm) while running may solve the problem.

When the problem repeats, an air-venthole can be drilled in the coupling adapter and a special gasket must be fitted. (see fig. 6.5).

When air is present, this will escape through the hole. When the fluid arrives, the special gasket will close the hole.

- Take part (1) (fig.6.6).
- Drill a 8mm hole in the cast boss on top of the coupling adapter.
- Deburr the hole.

- Place a special gasket (3) (Fig. 6.7)
- Mount the coupling adapter (1) to the pump (2).

Part numbers for special gaskets.

Coupling type:	part number:
V 65/ V 80	761-056
V 100	761-057
V 150	761-058

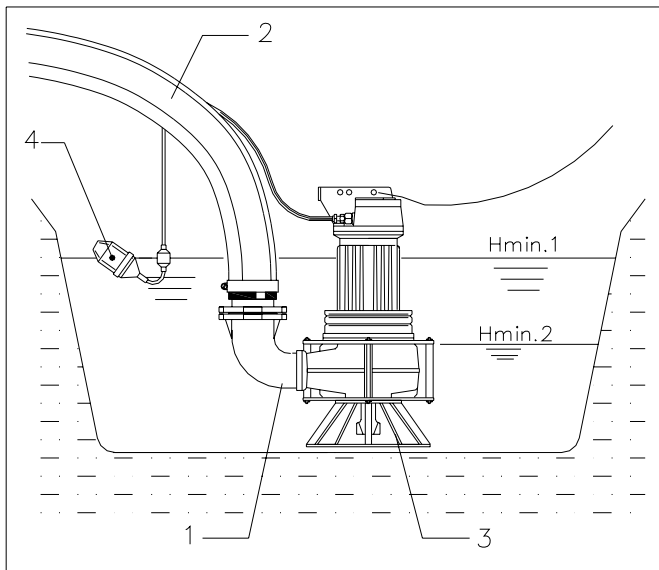

Fig. 6.8

## 6.4 INSTALLATION - F

Freestanding: semi-permanent fixed wet installation.

Except for the pump the following components are necessary:

1. Hose or threaded connection, which is fastened to the pump;
2. Flexible hose or pipe;
3. Pump support;
4. Level regulators.

Checkpoints before operating:

- Adjust the start- and stoplevels in such a way that the motor does not make more than 20 starts per hour.
- Check that the motor is adequately cooled. The motorhousing should be at least 2/3 submerged for continuous operation at full load (see Hmin.1 Fig. 6.8). It is good practice, whenever possible to keep the motorhousing completely under water.

For interrupted level controlled operation, less cooling is required.

We recommend not to run the pump with the water level below the top of the volute in order to avoid air being drawn in (see Hmin.2 Fig. 6.8).

Air in the discharge pipes might impair performance.

## 6.5 INSTALLATION - T

Transportable wet installation.

Except for the pump the following components are necessary:

1. Hose connection, which is fastened to the pump;
2. Flexible hose;
3. Pump support.

Checkpoints before operating:

- Do not let the pump bury itself in the mud.
- Do not leave a large loop of the cable in the sump, as the pump may eventually damage it.
- Check that the motor is adequately cooled. The motorhousing should be at least 2/3 submerged for continuous operation at full load (see Hmin.1 Fig. 6.9). It is good practice, whenever possible to keep the motorhousing completely under water.

For interrupted level controlled operation, less cooling is required.

We recommend not to run the pump with the water level below the top of the volute in order to avoid air being drawn in (see Hmin.2 Fig. 6.9).

Air in the discharge pipes might impair performance.

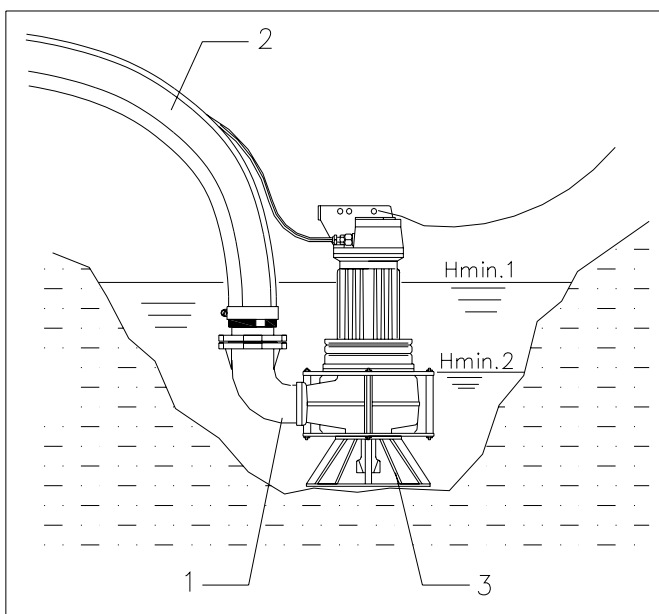

Fig. 6.9

## 7. MAINTENANCE

### 7.1 General



Always disconnect the pump from the mains before inspection or disassembly.



Clean the pump thoroughly.



The motor housing can be hot when the pump is just switched off.

### 7.2 Maintenance schedule

- \* After the first 20 running hours:
  - Check the oil (see chapter 7.5).  
If there is more than a few drops of water in it, contact your dealer.
- \* Every 6 months or 500 running hours:
  - Check the oil (see chapter 7.5).  
If there is more than a few cm<sup>3</sup> water in it, contact your dealer.
- Refresh the oil every year or when it is no longer transparent. (See chapter 7.6)

### 7.3 Lubricants

- \* The bearings are greased for life and need no refill.
- \* The oil reservoir is filled with ExxonMobil Marco1 152  
Viscosity: 32 cSt.  
When another kind of oil is used this is marked on a label on the pump.

Oil quantities:

RD 20:	0,6 L.
RD 40:	1,5 L.
RD 60:	2,4 L.

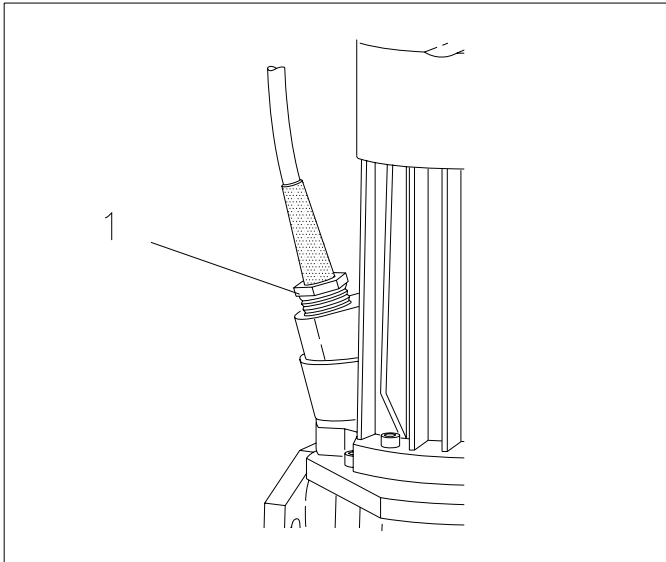

Fig. 7.1

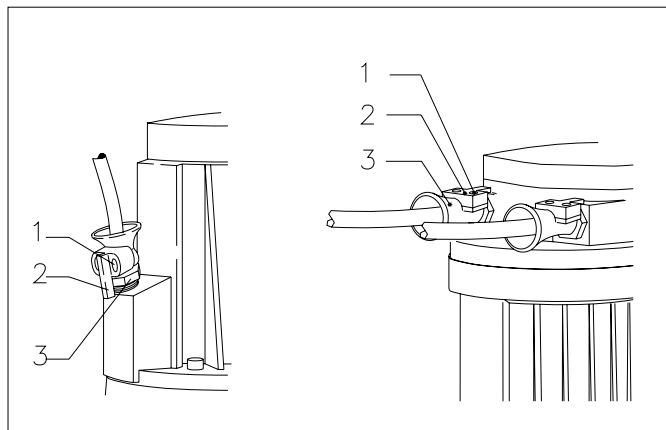

Fig. 7.2

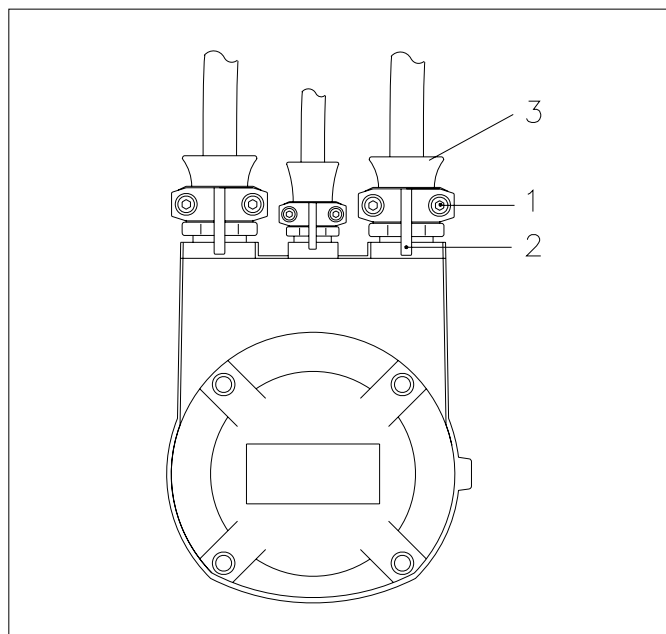

Fig. 7.3

## 7.4 Cable entry

Especially when the pump has been in use for a long time, the compression of the rubber cable seal might be diminished, which can cause leakage. By screwing-in the cable entry the seal will be retained.

### 7.4.1 RD 20

Turn the hexagon head of the entry (1) for 1/6 of a turn clockwise using the right tool.

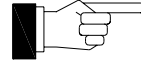

It is possible that your cable entry is fitted with a cable clamp.  
See 7.4.2.

### 7.4.2 RD 40

Unscrew the 2 hexagon socket screws (1).

Remove the cable clamp (2).

Turn the hexagon head of the entry (1) clockwise, using the right tool, so far that it is possible to replace the cable clamp again.

Screw-in the 2 hexagon socket screws (1).

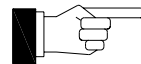

It is possible that your pump is fitted with 2 cables.

### 7.4.3 RD 60

Unscrew the 4 hexagon socket screws (1) from the outer cable entries.

Remove the cable clamps (2).

Turn the hexagon heads of the entry clockwise, using the right tool, so far that it is possible to replace the cable clamps again.

Screw-in the 4 hexagon socket screws (1).

Turn the hexagon head of the middle entry (3) for 1/6 of a turn clockwise.

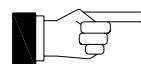

It is possible that your pump is fitted with only 2 cables.

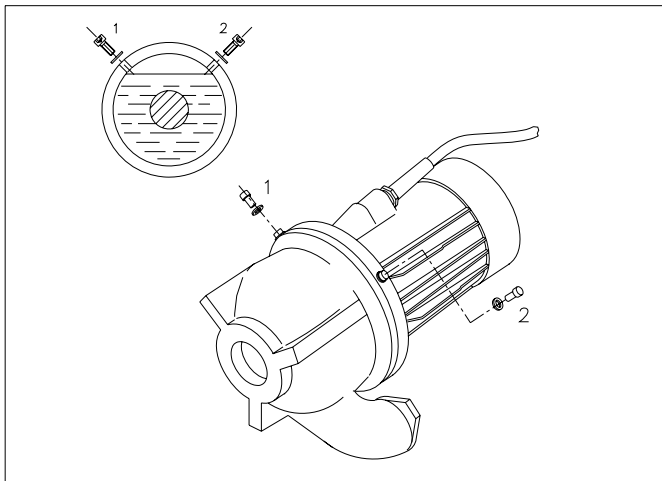

Fig. 7.4

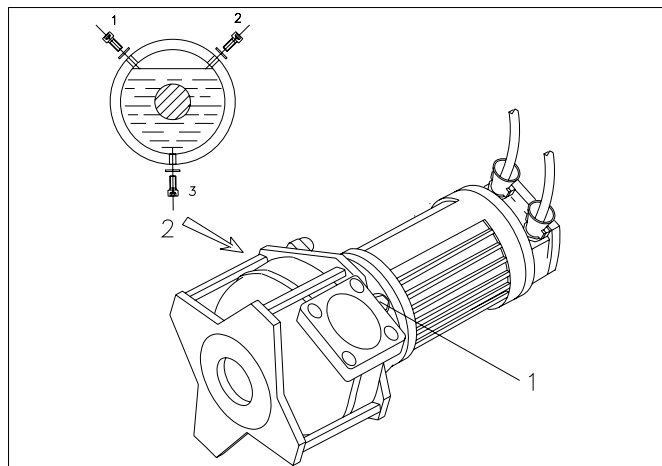

Fig. 7.5

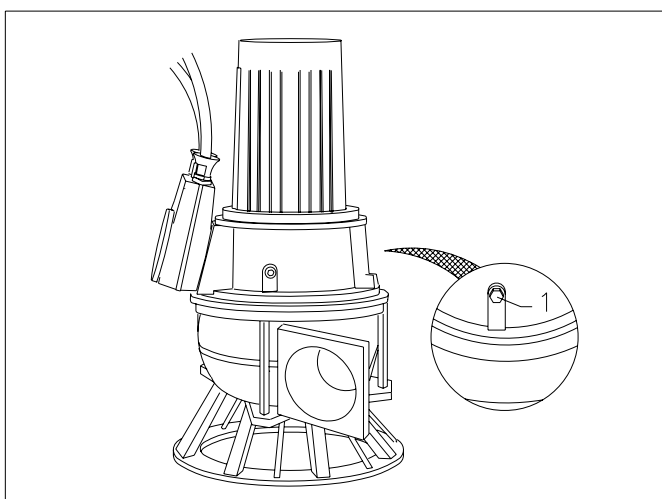

Fig. 7.6

## 7.5 Oil level

### 7.5.1 RD 20

Put the pump in a horizontal position so that the 2 hexagonal socket screws are on top (see fig.7.4). Unscrew the level plug (1) and the vent plug (2).

The oil level should be at the lower side of the openings (see drawing).

By turning the pump a bit this should be visible. If not so fill up to the right level.

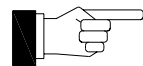

Always use the right kind of oil !

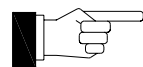

It is possible that your pump is fitted with 3 plugs.  
For oil check see 7.5.2

### 7.5.2 RD 40

Put the pump in a horizontal position so that 2 hexagonal socket screws are on top and one at the bottom (see fig.7.5).

Unscrew the level plug (1) and the vent plug (2).

The oil level should be at the lower side of the openings (see drawing). By turning the pump a bit this should be visible.

If not so fill up to the right level.

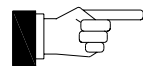

Always use the right kind of oil !

### 7.5.3 RD 60

Put the pump in a vertical position.

Unscrew the M20 oil plug (1) which can be found at the opposite side of the cable entry box (see fig. 7.6).

The oil level should be at the lower side of the opening. If not so fill up to the right level.

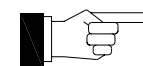

Always use the right kind of oil !



Ensure that the pump is fully supported to prevent it from falling over !

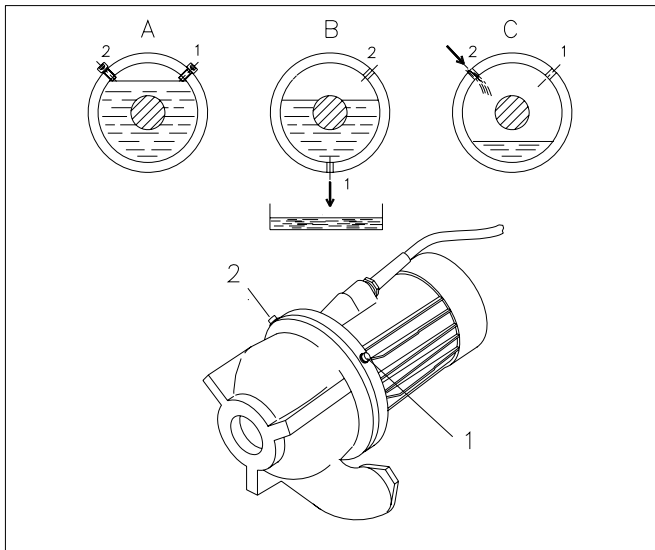

Fig. 7.7

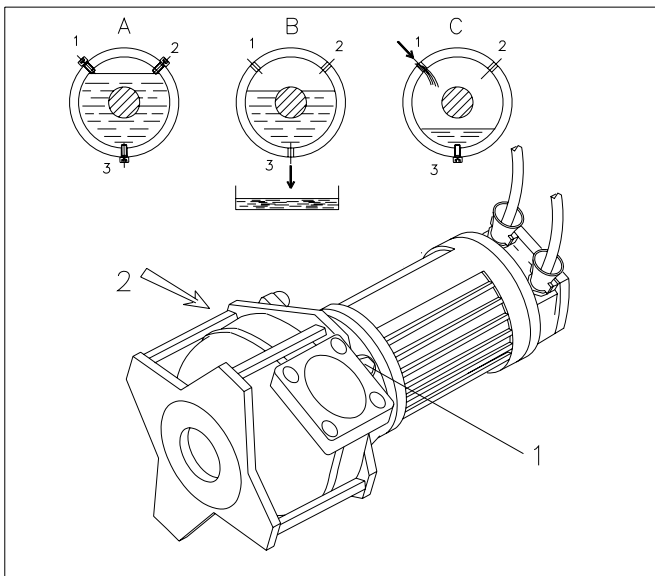

Fig. 7.8

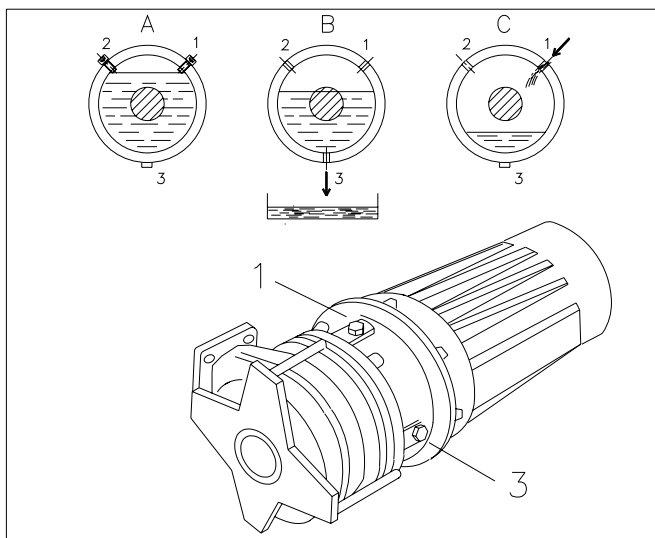
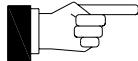
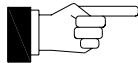
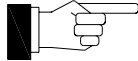

Fig. 7.9

## 7.6 Oil change

-  Collection, storage and removal of the oil should be done according to the regulations of the local authorities.
-  When necessary replace the sealing rings.
-  Always use the right kind of oil ! (see chapter 7.3).

### 7.6.1 RD 20

Put the pump in a horizontal position so that one of oil plugs is at the bottom ( fig.7.7 position B).  
Remove the vent plug (2).  
Put a receiving bin underneath the drain plug (1).  
Remove the plug and drain the oil.  
Rotate the pump so that the 2 openings are on top (fig.7.7 position C).

Refill the oilhousing.  
The oil level should be at the lower side of the openings. (fig.7.7 position A).

Replace the plugs.

### 7.6.2 RD 40

Put the pump in a horizontal position so that the drain plug (3) is at the bottom (Fig.7.8 position A).  
Remove the vent plugs (1) and (2).  
Put a receiving bin underneath the drain plug.  
Remove the plug and drain the oil.

Replace the drain plug.

Refill the oilhousing.  
The oil level should be at the lower side of the openings (Fig.7.8 position A).

Replace the plugs.

### 7.6.3 RD 60

Put the pump in a horizontal position so that the drain plug (M20) is at the bottom (Fig.7.9 pos. A).  
Remove the vent plugs (1) and (2).  
Put a receiving bin underneath the drain plug.  
Remove the plug and drain the oil.

Replace the drain plug (3).

Refill the oilhousing through the opening (1).  
The oil level should be at the lower side of the opening (Fig.7.9 position A).



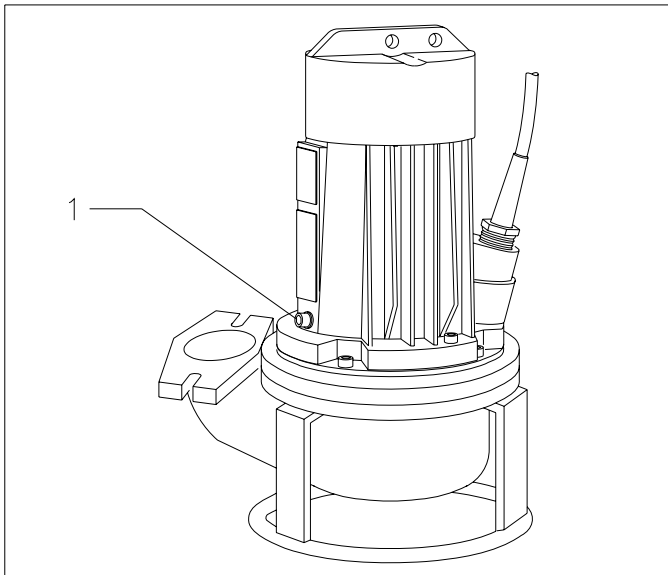

Fig. 7.10

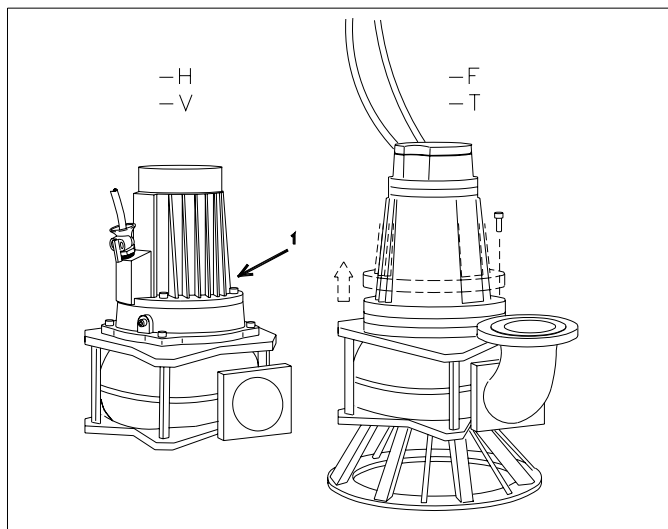

Fig. 7.11

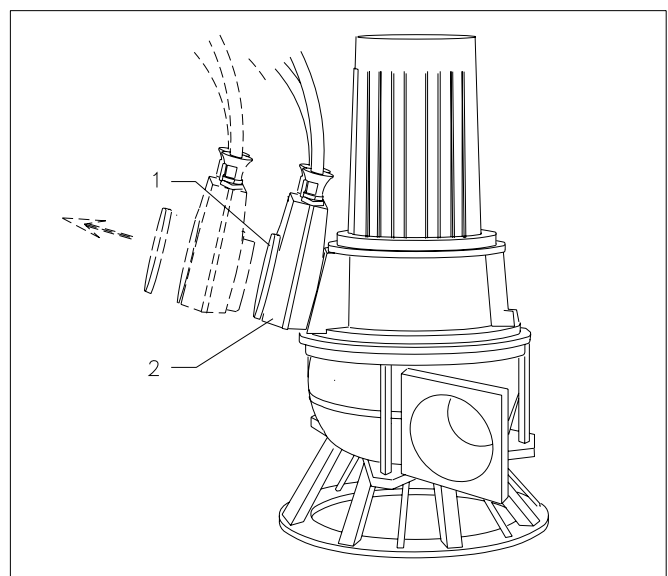

Fig. 7.12

## 7.7 Motor housing

### 7.7.1 RD 20

Unscrew the inspection plug of the motorhousing (see Fig. 7.10 pos 1).

Put the pump in horizontal position with the inspection opening downwards.

If water is present this will come out this way.

A small amount of water, due to condensation, is permissible.

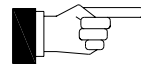

More water is an indication of leakage of the construction. Oil is an indication of seal failure between motorhousing and oil chamber.

If so, contact your dealer.

### 7.7.2 RD 40

Installation -H,-V:

Unscrew the inspection plug of the motorhousing (see Fig. 7.11 pos 1).

Installation -F,-T:

Place the pump in a vertical position and remove the 4 hexagonal socket screws of the motorhousing.

Lift the pump very carefully a few cm's, see fig. 7.11.

If water is present this will come out this way.

A small amount of water, due to condensation, is permissible.

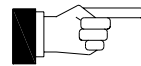

More water is an indication of leakage of the construction. Oil is an indication of seal failure between motorhousing and oil chamber.

If so, contact your dealer.

### 7.7.3 RD 60

Place the pump in a vertical position and remove the 4 hexagon socket screws (1) of the cable entry box cover (2) and check the entry box.

Remove the 4 hexagon socket screws (1) of the cable entry box and pull the cable entry box a few cm's from the pump.

If water is present this will come out this way.

A small amount of water, due to condensation, is permissible.

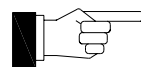

More water is an indication of leakage of the construction. Oil is an indication of seal failure between motorhousing and oil chamber.

If so, contact your dealer.

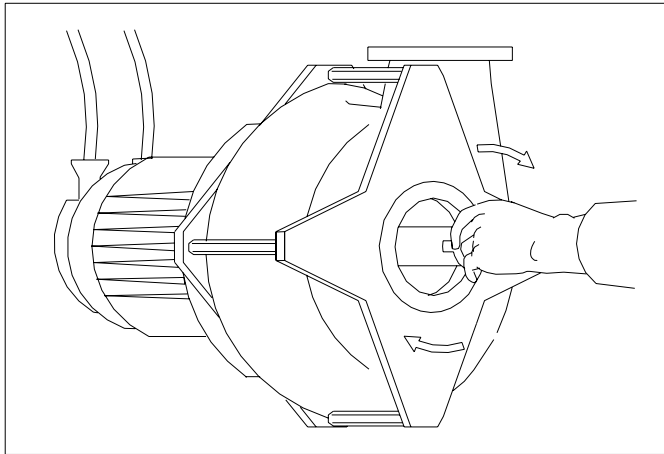

Fig. 8.1

## 8. TRANSPORT AND STORAGE

The pump can be transported and stored in both horizontal and vertical position.



Never lift the pump by the motorcable or discharge hose!  
Always use the suspension bracket !

In case of long storage, the pump must be protected against moisture and heat.

Before storing the pump clean it with a waterjet and check the motor housing for water ingress (see chapter 7.7) .

On a regular base (every three months), turn the impeller by hand, this is necessary to prevent sticking of the mechanical seal surfaces (see Fig. 8.1).

After 6 months of storage, a general inspection is advised, before installing the pump.

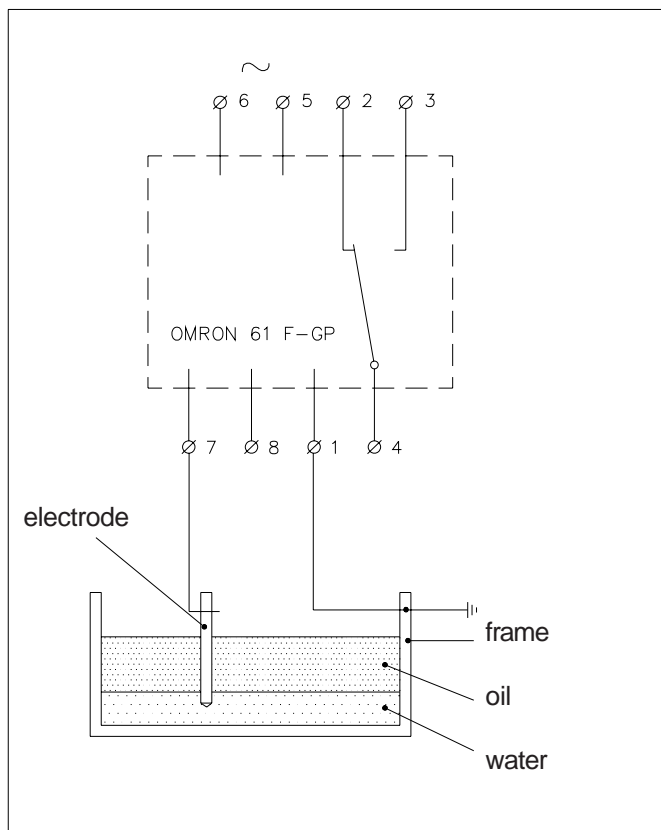

Fig. 9.1

## 9. OPTIONS

### 9.1 Waterdetector

As a safeguard against water ingress into the motor, the pump can be equipped with a waterdetector.

When your pump is equipped with a waterdetector, this can be found on the dataplate.

See appendix 1: at position 24 a "W" is stamped.

The waterdetector detects water which might have entered the oilhousing or motorhousing due to seal failure or cable damage.

The waterdetector causes the pump to switch off, before damage to the motor is done.

The probe itself is a non-active electrode, placed in oil and motorhousing. It is used in conjunction with a relay in the control circuit that measures the resistance between probe and frame.

If only air or oil is present, the resistance is over 5000 Ohm. If water enters, the resistance will decrease to as low as 300 to 500 Ohm

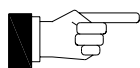
 We advise to use OMRON relay 61 F-GP or an equivalent. This relay switches at 5000 ohm.

No water present:

- high resistance between terminals 1 and 7 (>5000 Ohm)
- terminals 2 and 4 closed
- terminals 3 and 4 open

Water present:

- low resistance between terminals 1 and 7 (300-500 Ohm)
- terminals 2 and 4 open
- terminals 3 and 4 closed

### 9.2 Thermoswitches

Thermoswitches are standard for the RD60 pumps and optional for the RD20 and RD40.

When your pump is equipped with thermoswitches, a "T" is stamped at position 24 on the dataplate. (see appendix 1). A copy of your dataplate is on page 2.

For connection values see par. 5.4.

### 9.3 Thermistors

Instead of thermoswitches, the pump can be equipped with thermistors (on special request).

This will be marked with a "U" on the dataplate at position 24 .

Normally the resistance is about 200-500 Ohm.

When the switch-off temperature is reached the resistance will be between 1650-4000 Ohm.

The maximum voltage is 7.5V.

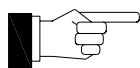
 A thermistor is not a circuit breaker but a resistance.

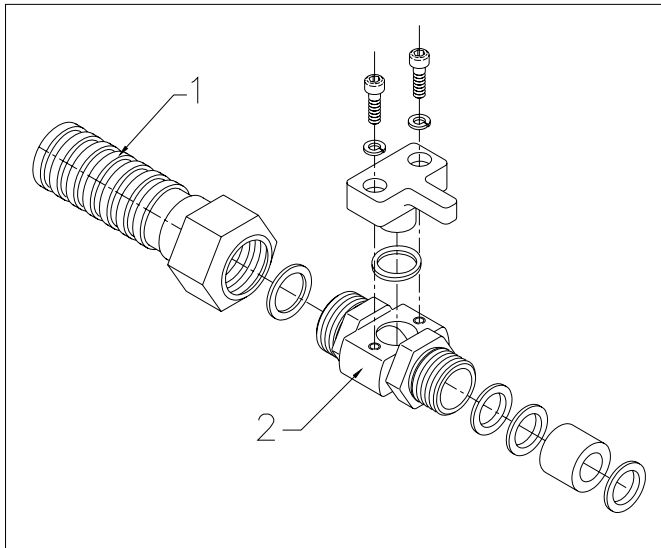

Fig. 9.2

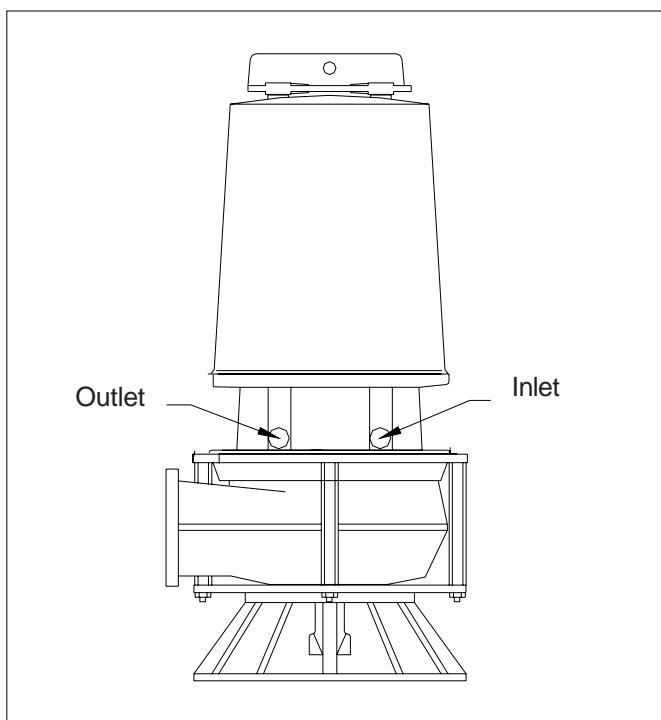

Fig. 9.3

#### 9.4 Cable protection

When chemical or mechanical protection for the cable is needed a tube can be fitted around the cable (Fig. 9.2 pos 1).

This is a flexible stainless steel tube (1) connected to a special cable entry (Fig.9.2 pos 2).

When your pump is equipped with a cable protection, a "3" is stamped on the dataplate at position 24. See appendix 1.

#### 9.5 Special oil

Upon request the oil housing can be filled with a special oil. If so, a label on the pump shows which kind of oil is used.

#### 9.6 External cooling system

As an option the pump could be obtained with a external cooling system. In this case a motorhousing with cooling jacket is installed. At least 20 l/min water with a maximum temperature of 40°C and about 1 bar pressure is circulated through the cooling jacket.

For this purpose two 1/2" connections are supplied on the bearinghousing.

The right-hand site is the inlet opening.

The cooling system is self-venting, providing that in and outlet are not exchanged.

The cooling flow is only required while the pump is running.

If the cooling water temperature exceeds 45°C the amount of cooling water should be established on site. The difference between in and outlet temperature should be less than 10°C.

The maximum medium temperature should not exceed 80°C.

Alternatively the pump could be ordered in a version that discharges the cooling water through the pump. With this arrangement, the mechanical seal and the backside of the impeller are kept clear from dirt contaminations. The required cooling water pressure varies with pump type and operating conditions. It will not exceed the suction pressure plus 2/3 of the manometric pumphead.

## 10. TROUBLE SHOOTING

### 10.1 Safety



When working on the motor, make sure that the power is switched off.



Only qualified electricians may do the electrical work.



When working on the pump make sure it cannot start unexpectedly!



When starting the pump ensure nobody goes near rotating parts.

**Observe local electrical and safety regulations!**

### 10.2 Trouble shooting list

PROBLEM	POSSIBLE CAUSE	REQUIRED ACTION	CHECKPOINTS
Pump does not start	No voltage on motor terminals	Check power supply	* No power * Main isolator switch * Fuses
		Check motor protection	* Earth leakage relay * Motor protection relay * Motor temperature * Water detector
	Check start-and stop signals	* Too low waterlevel * Obstructed level switches * Switches interchanged * Control panel	
	Motor failure	Check motor wiring	* Continuity and isolation * Phase resistance
Pump does not stop	No stop signal	Check level regulation	* Float switches * Control panel
	Wrong start- and stop level	Check level regulation	* Obstructed level switches * Adjust start- and stop level * Power supply not stable
Pump starts and stops repeatedly	Fault in power supply	Check power supply	* Low voltage * Not all 3 phases available * Setting of motor protection
	Motor overloaded	Check pump	* Wrong direction of rotation * Impeller blocked * Protection in automatic reset mode
	Motor overheated	Check cooling Check motor	* Continuity and isolation * Fuses
Current too high	Fault in power supply	Check power supply	* Low voltage
	Pump failure	Check pump	* Impeller blocked * Viscosity or spec. gravity too high * Wrong direction of rotation
Pump runs but no flow or too low flow	Clogging or air lock	Check discharge and coupling	* Discharge obstructed * Valve fully or partly closed * Air pocket in pump or discharge * Coupling leaks
	Pump failure	Check pump	* Impeller or volute blocked * Pump is sucking too much air * Worn or broken impeller
	Fault in power supply	Check power supply	* Control panel * Fuses * Low voltage
	Too low capacity	Check discharge	* Discharge obstructed * Valve fully or partly closed * Air pocket
High level alarm	Pump failure	Check pump	* Impeller or volute blocked * Pump is sucking too much air * Worn or broken impeller * Worn or broken bearings
	Fault in power supply	Check power supply	* Fuses * Control panel
	Motor failure	Check motor	* Continuity and isolation

## APPENDIX 1: Dataplate

The main characteristics of the pump are given on the dataplate.  
At the first page of this book a label is found containing all the relevant information.

The dataplate of an RD20 pump can be found on the motorhousing at the opposite side of the cable entry.  
The dataplate of an RD40 pump is at one of the side of the motorhousing.  
The dataplate of an RD60 pump can be found on the cable entry box.

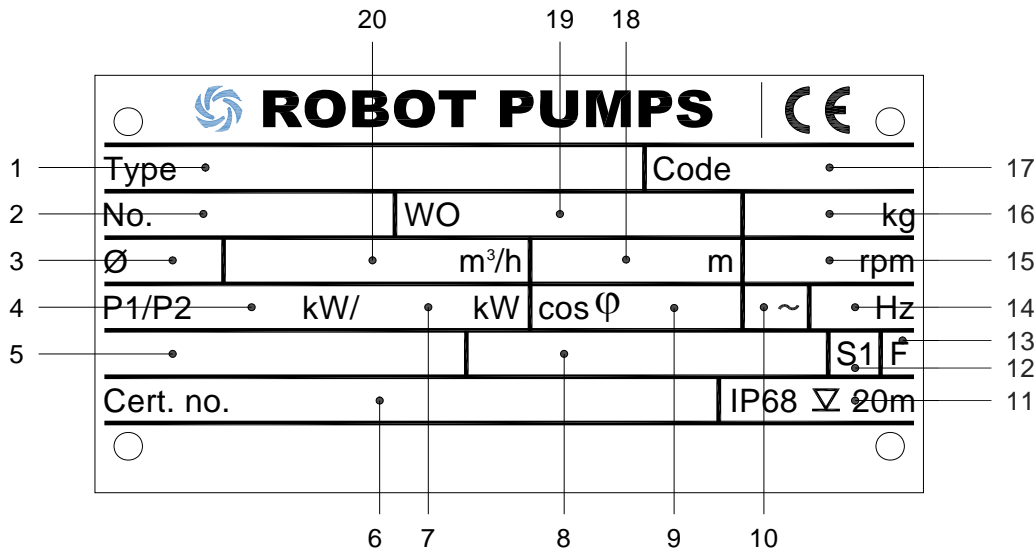

Nr. Description	Units	Remarks
1 Pump type		
2 Serial number		first 2 numbers are year of production
3 Impeller diameter	mm	
4 Rated electrical power	kW	
5 Rated voltage, current and connection	V, A	Y = motor in star
6 Certificate number		only for flame proof pumps
7 Rated shaft power	kW	
8 Rated voltage, current and connection	V, A	Δ = motor in delta.
9 Power factor		
10 Number of phases		
11 Degree of protection		submersible (20m)
12 Type of duty cycle		S1 =continue
13 Temperature class		F =155°C
14 Frequency	Hz	
15 Speed	rpm	
16 Pump weight	kg	excl. accessories
17 Pumpcode		
18 Head in duty point	mlc	
19 Factory code		
20 Capacity in duty point	m <sup>3</sup> /h	

APPENDIX 2; Direct-on-line start motor (DOL)

PUMP CABLE CONNECTIONS

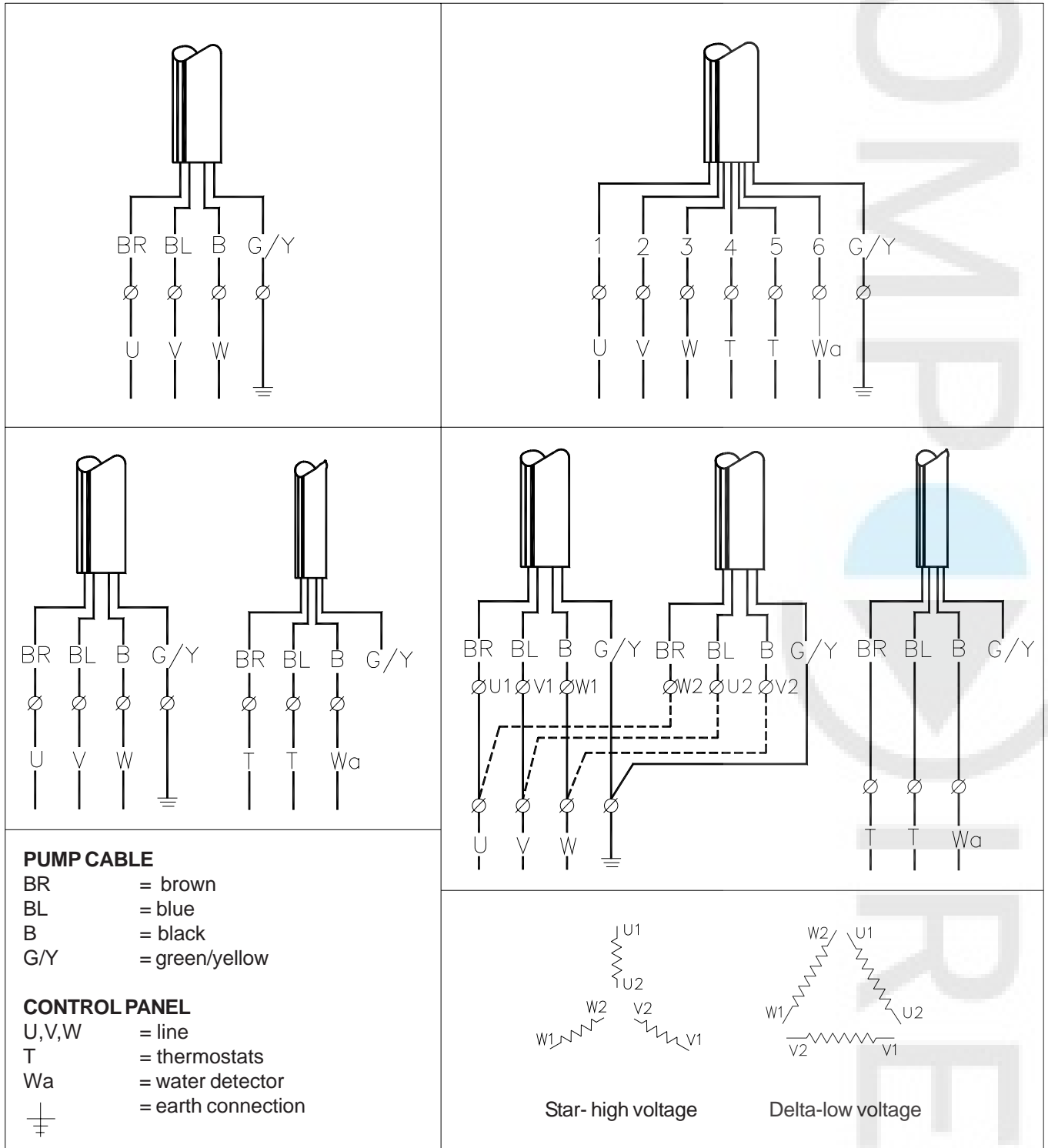

In some situations where a longer pump cable is used an extra 10 mm<sup>2</sup> earth cable is fitted to the motor housing to fulfill the demands of the Low Voltage Directive. Always connect this cable also to the earth connection!

EXAMPLE OF A DIRECT-ON-LINE CONNECTION DIAGRAM

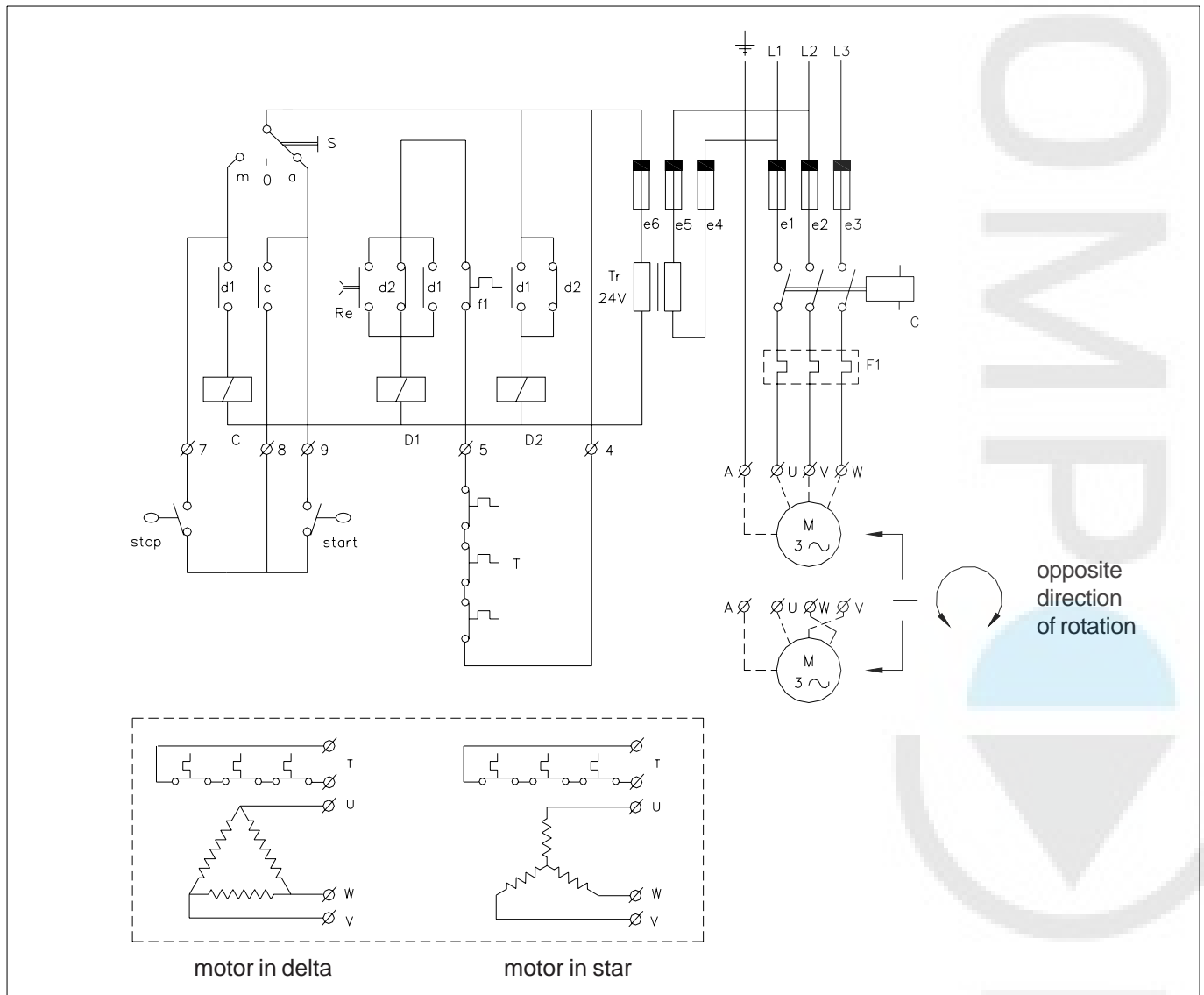

CODING	
e1, e2, e3	Line fuses
e4, e5	Fuses, primary control-circuit
e6	Fuses, secondary control-circuit
C	Maincontactor
F1	Motor protection circuit breaker with manual reset
D1	Auxiliary relay for motor protection
D2	Auxiliary relay for power failure
Tr	Transformer
S	Manual-off -auto selector switch
Start	Level switch pump start
Stop	Level switch pump stop
Re	Reset push button
M	Pump motor
T	Thermostats (if fitted)



APPENDIX 3; Star-delta start motor (YD)

PUMP CABLE CONNECTIONS

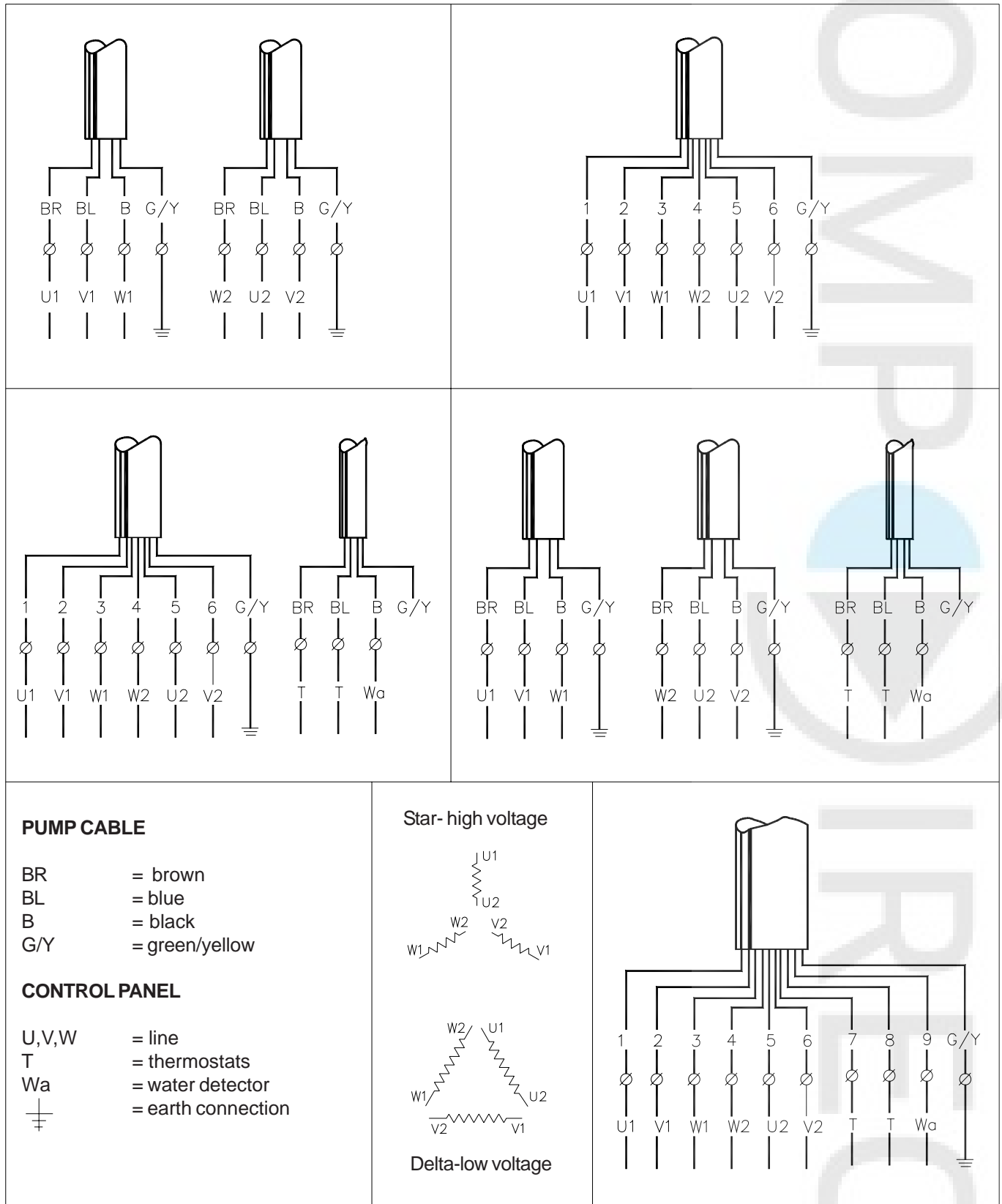

In some situations where a longer pump cable is used an extra 10 mm<sup>2</sup> earth cable is fitted to the motorhousing to fulfill the demands of the Low Voltage Directive. Always connect this cable also to the earth connection!

EXAMPLE OF A STAR-DELTA CONNECTION DIAGRAM

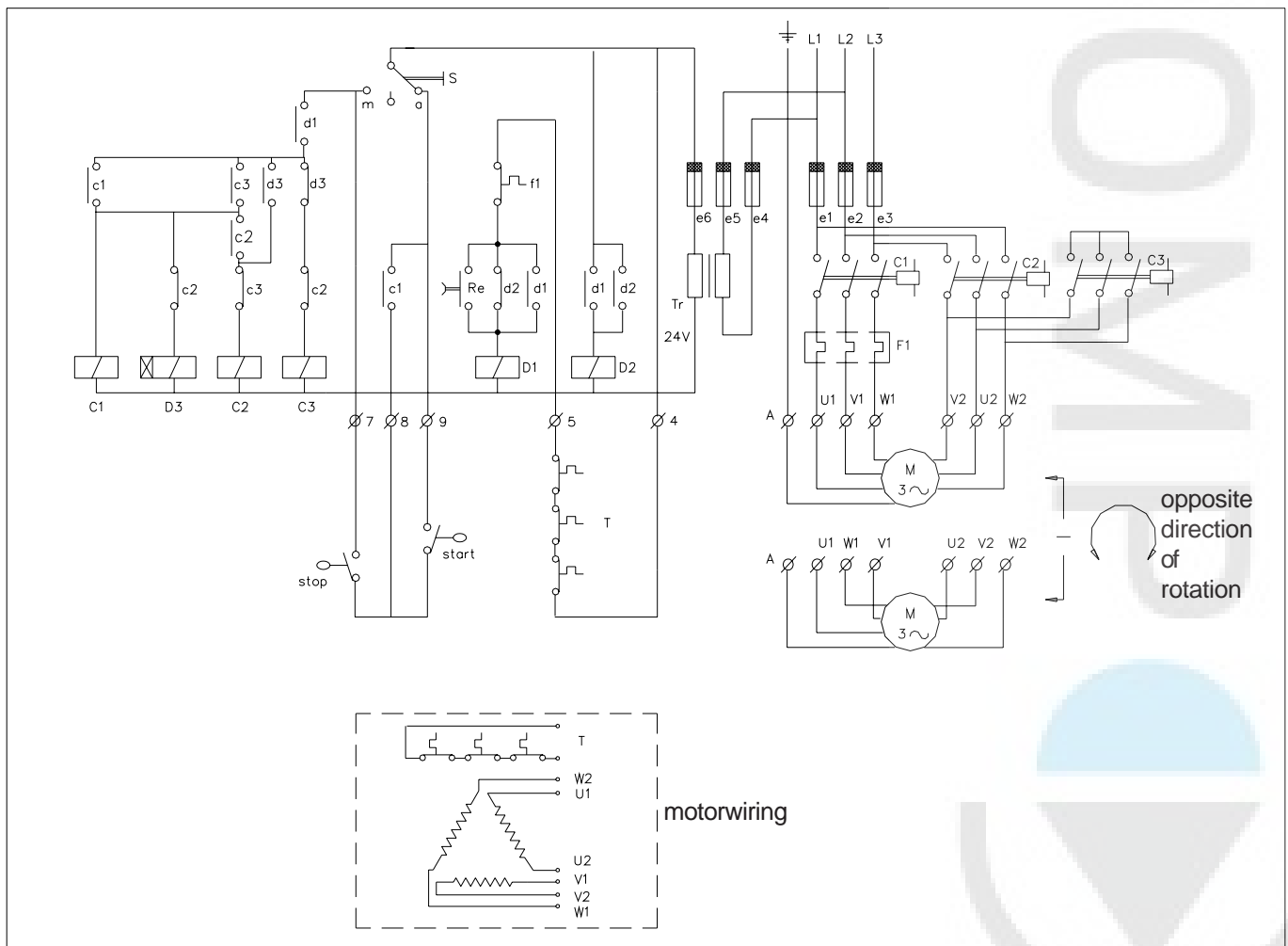

CODING	
e1, e2, e3	Line fuses
e4, e5	Fuses, primary control-circuit
e6	Fuses, secondary control-circuit
F1	Motor protection circuit breaker with manual reset
C1	Maincontactor
C2	Relay delta connection
C3	Relay star connection
D1	Auxiliary relay for motor protection
D2	Auxiliary relay for power failure
D3	Timer relay star-delta start
Tr	Transformer
S	Manual-off-auto selector switch
Start	Level switch pump start
Stop	Level switch pump stop
Re	Reset push button
M	Pump motor
T	Thermostats (if fitted)

